

0 10 20 30 40 50 60 70 80 90 100

ASSEMBLY: X-XXXX-XXX
 THIS DRAWING IS UNCLASSIFIED BY DATE 10/10/2000
 AND ALL RIGHTS WHERE THERE IN ARE EXPRESSLY RESERVED BY ACCEPTING THE MATERIAL HEREIN FOR REPRODUCTION OR TRANSMISSION IN ANY MANNER TO OTHERS WITHOUT THE EXPRESS WRITTEN PERMISSION OF UAV-PILOTS DE
 REPRODUCED IN ANY MANNER TO OTHERS WITHOUT THE EXPRESS WRITTEN PERMISSION OF UAV-PILOTS DE

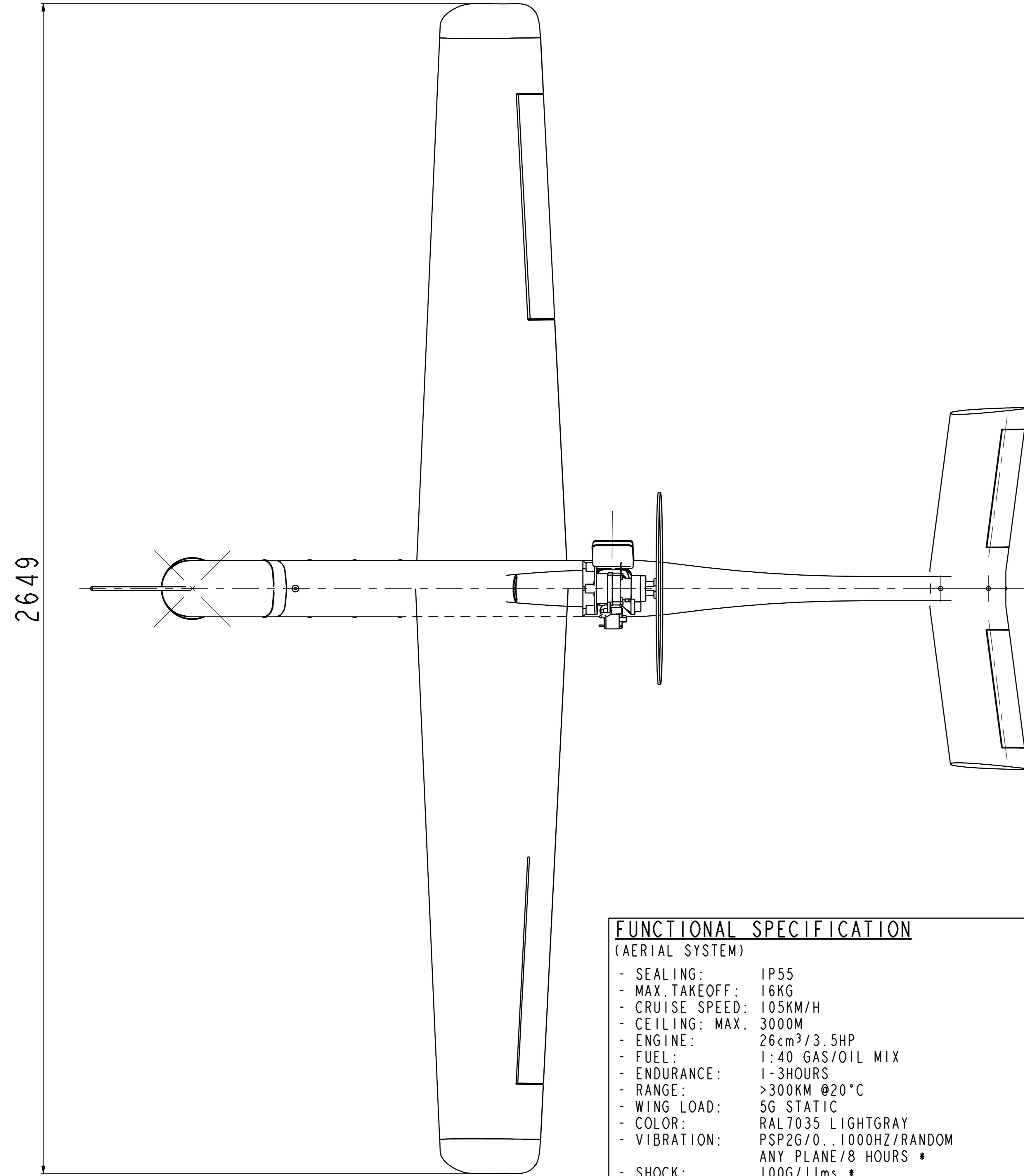
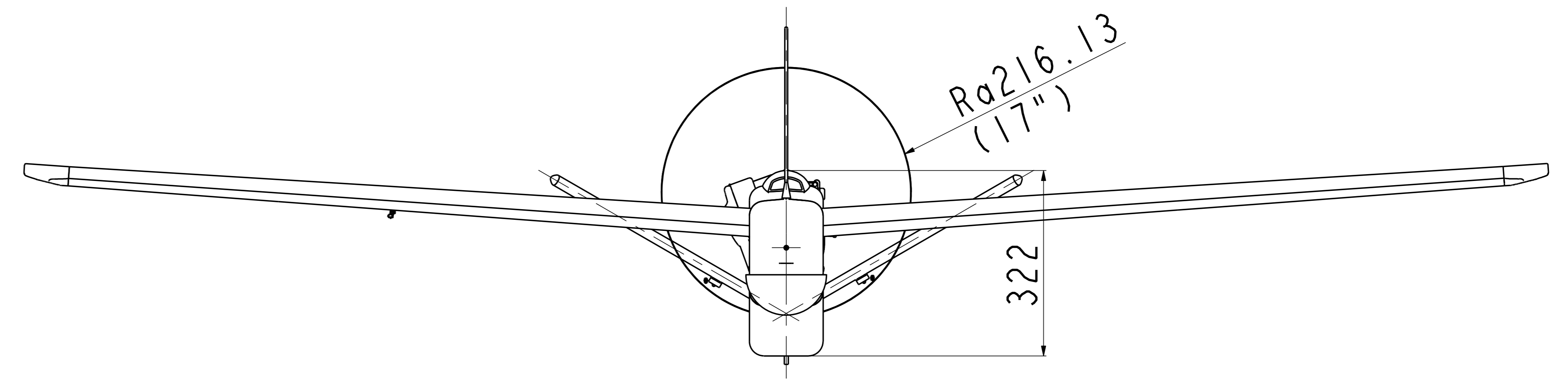
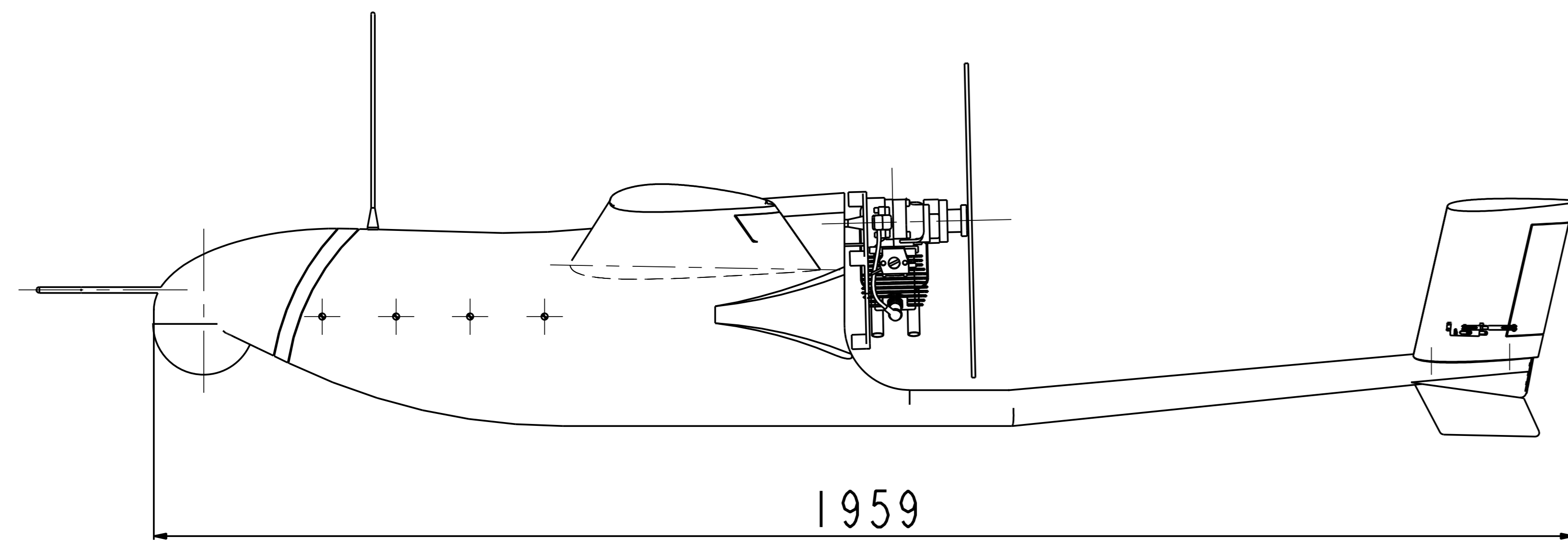

FUNCTIONAL SPECIFICATION
 (AERIAL SYSTEM)

- SEALING: IP55
- MAX. TAKEOFF: 16KG
- CRUISE SPEED: 105KM/H
- CEILING: MAX. 3000M
- ENGINE: 26cm³/3.5HP
- FUEL: 1:40 GAS/OIL MIX
- ENDURANCE: 1-3HOURS
- RANGE: >300KM @20°C
- WING LOAD: 5G STATIC
- COLOR: RAL7035 LIGHTGRAY
- VIBRATION: PSP2G/0...1000HZ/RANDOM ANY PLANE/8 HOURS *
- SHOCK: 100G/11ms *
- HUMIDITY: 95% NON CONDENSING
- OPERATING TEMPERATURE: 0°C-40°C *
- STORAGE TEMPERATURE: -10°C-50°C *
- * RATING OF MOST SENSITIVE COMPONENTS ALL SPECIFICATIONS NOMINAL AT 20°C EXCEPT WHERE STATED.

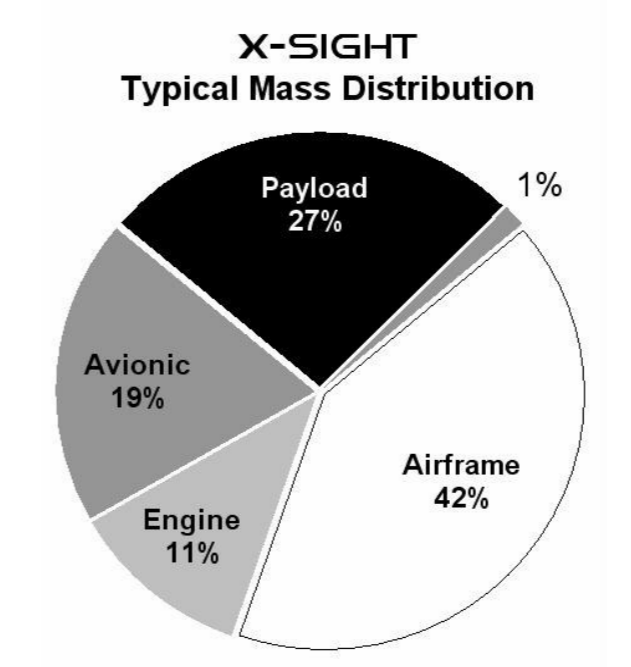
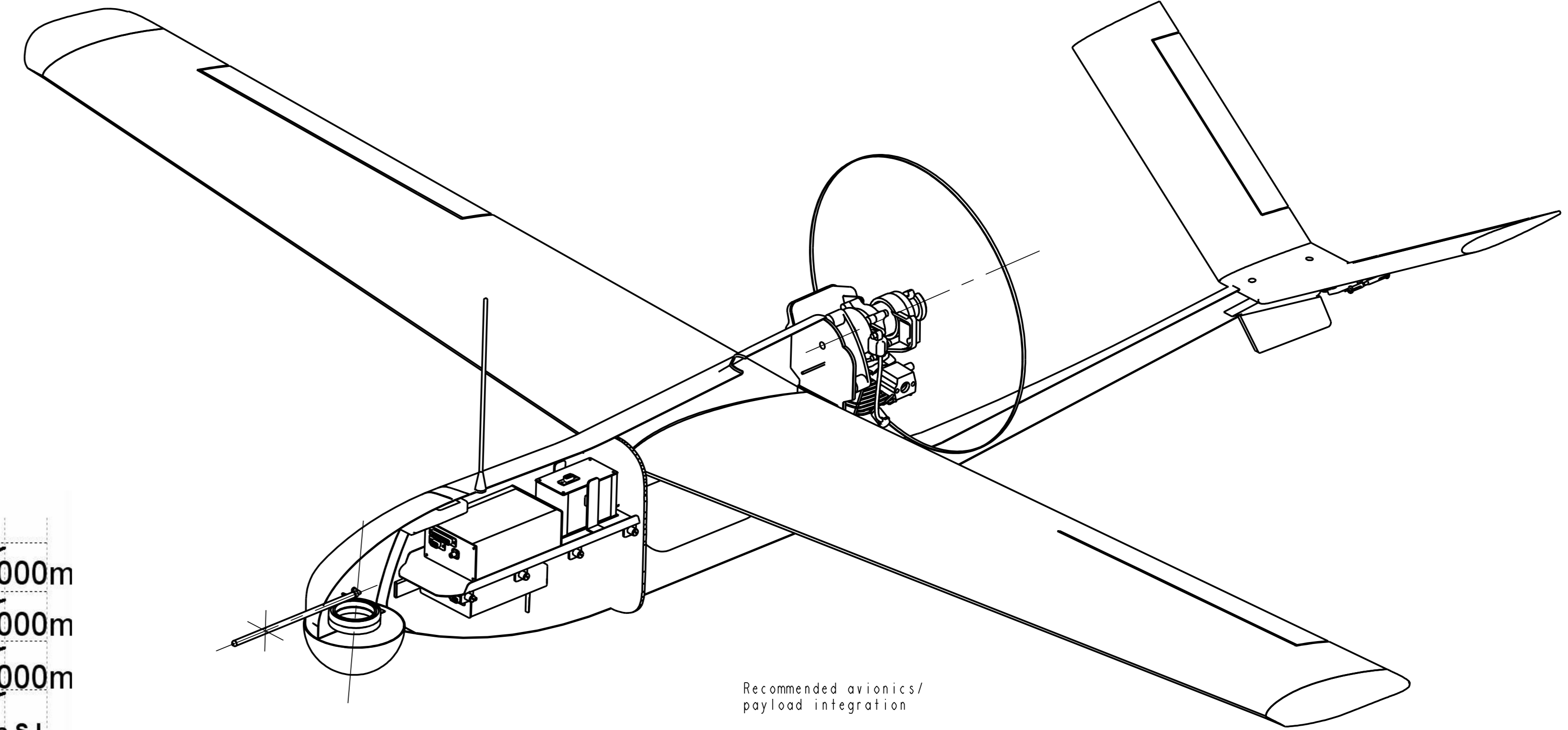
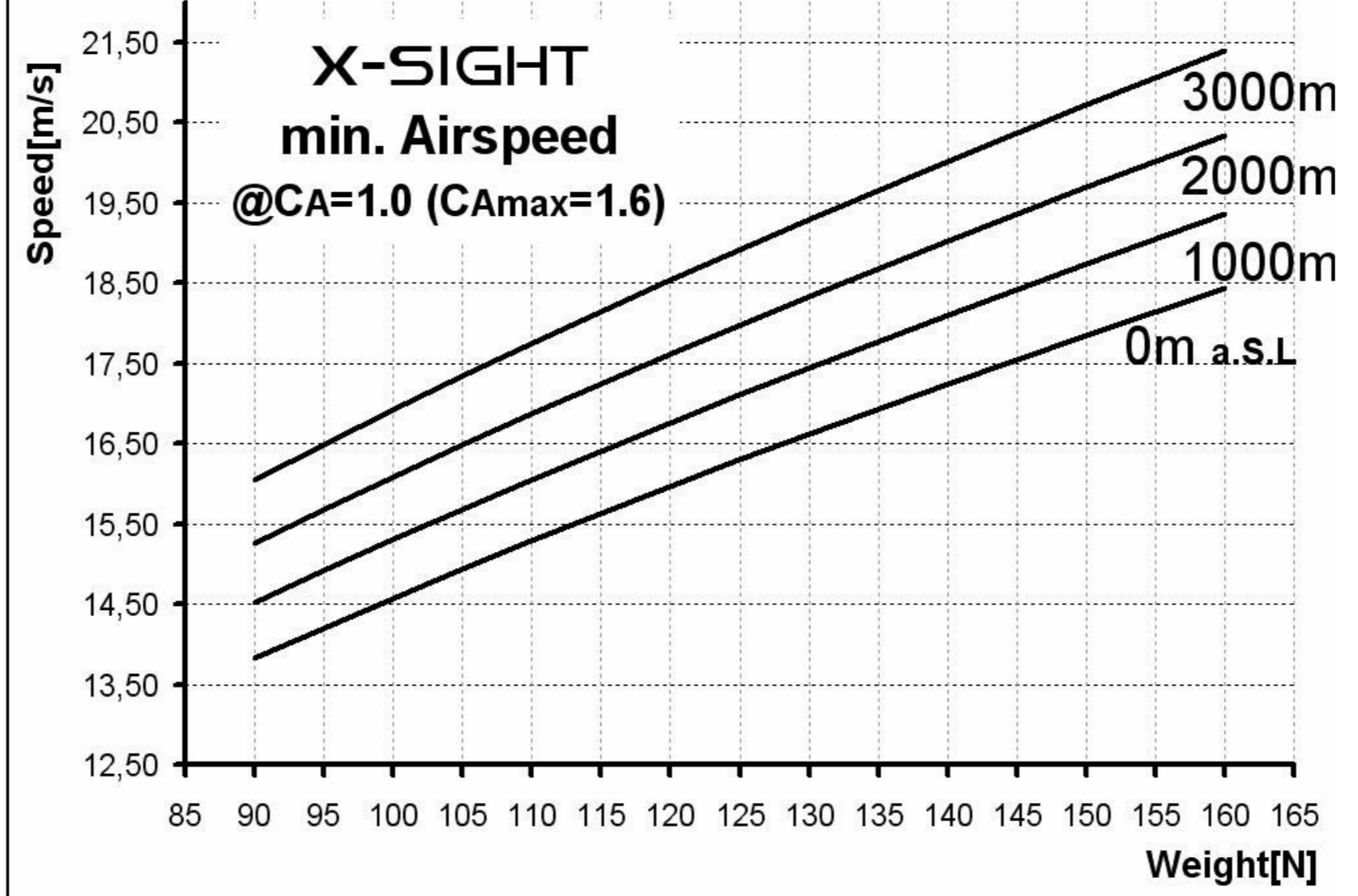

CUSTOMER DRAWING
 -Copyright reserved by UAV-Autopilots.de-
 -Copyright reserved by german trademark-

Original format: AD	2005	Date	Name	Airframe Assembly
Scale: 1:1	20.08.2005	22.02.	Sabatini	X-SIGHT UAV
Appr.: [Signature]	FZ 3.00000.103			
Rev.	Date	Name	WEIGHT: MAX. TAKEOFF 15kg	

Sheet 3/14